

PAD



18 mm min.

1 - Make $\varnothing 8$ mm edge borings on the panel thickness using an appropriate template for driver-drill.

2 - Make $\varnothing 5$ mm face borings on the other panel.

3 - Screw the assembly fitting into the face bored panel using a cross screwdriver.

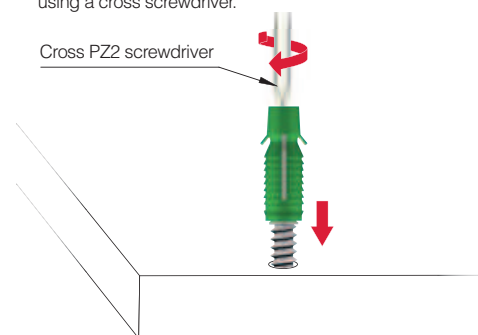
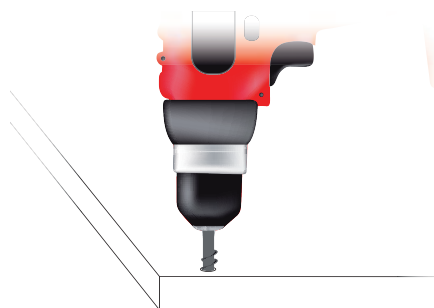
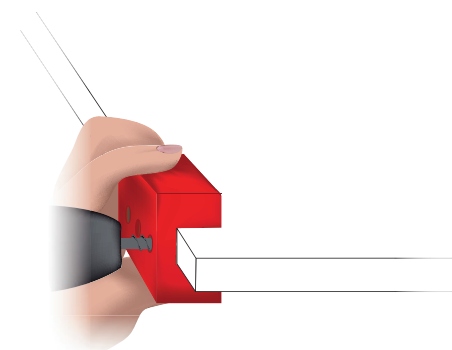

4 - Push manually the edge bored panel against the fitting until it is totally inserted.

5 - The two panels will be permanently assembled without using any kind of glue.

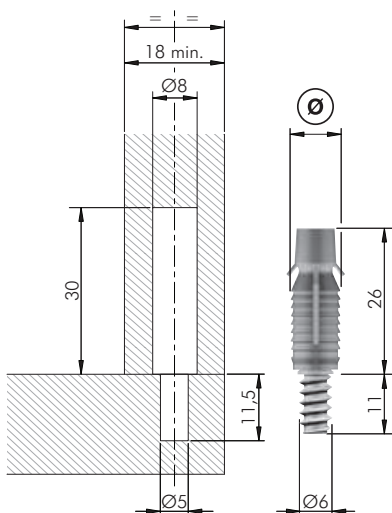
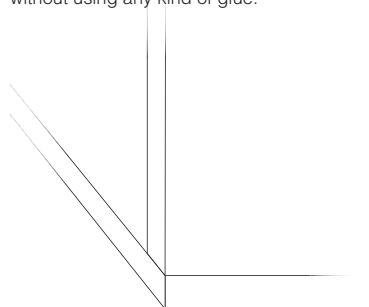
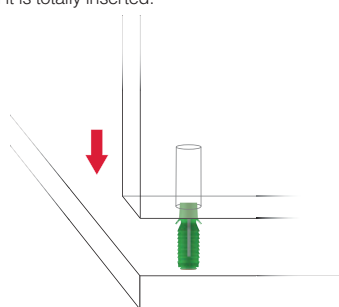

= $\varnothing 5$ mm	= PZ2
ST EP	= 2500 pcs.
2162300000	9,3
2162301000	8,8